

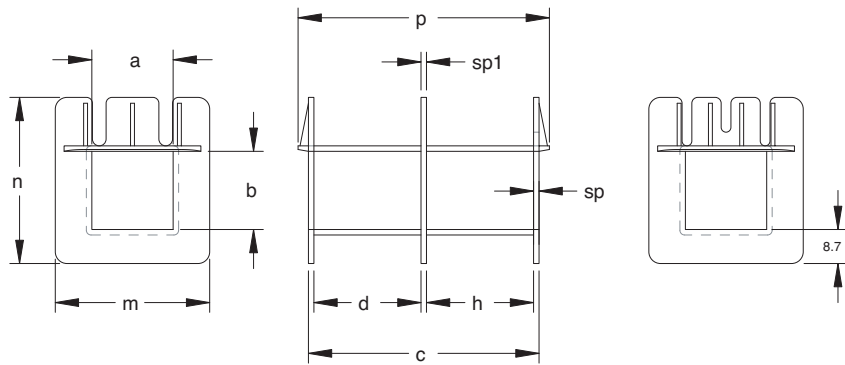

UI 60 BOBBINS



Bobbin Size	Type	a	b	c	d	h	sp/sp1	m	n	p	Part No
UI 60/20	SS	20,6	21.0	60.0			1,5	38.0	42,5	64.0	U0600201
UI 60/20	DS	20,6	21.0	60.0	27.0	27.0	1,5	38.0	42,5	64.0	U0600202
UI 60/30	SS	20,6	30.0	60.0			1,5	38.0	57.0	66.0	U0600301
UI 60/30	DS	20,6	30.0	60.0	27.0	27.0	1,5	38.0	57.0	66.0	U0600302

Standard material: Nylon 6 glass reinforced

Dimensions in millimetres

UI 66 BOBBINS

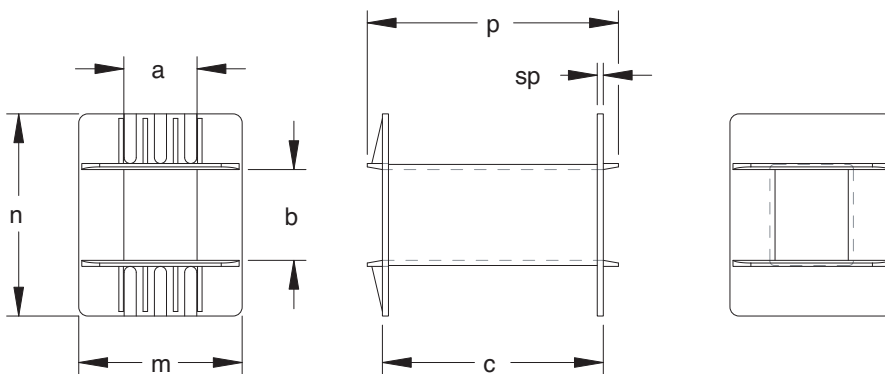

Bobbin Size	Type	a	b	c	sp	m	n	p	Part No
UI 66/30	SS	23,6	30.0	66.0	1,5	54,5	68.0	74.0	U0660303
UI 66/40	SS	23,6	40.0	66.0	1,5	54,5	74.0	74.0	U0660403
UI 66/45	SS	23,6	45.0	66.0	1,5	54,5	80.0	74.0	U0660453

Standard material: Nylon 6 glass reinforced

Dimensions in millimetres



Metric Range

UI 75 BOBBINS

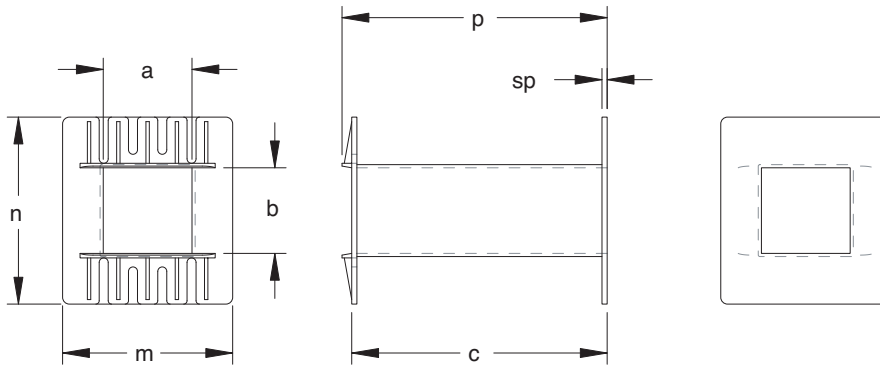

Bobbin Size	Type	a	b	c	sp	m	n	p	Part No
UI 75/26	SS	25,6	26,0	74,0	1,3	49,0	57,5	78,0	U0750263
UI 75/40	SS	25,6	41,0	74,0	1,3	49,0	73,0	78,0	U0750413

Standard material: Nylon 6 glass reinforced

Dimensions in millimetres

UI 90 BOBBINS

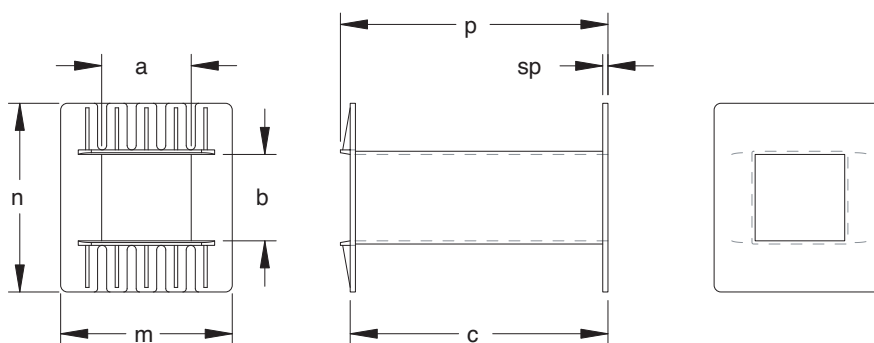

Bobbin Size	Type	a	b	c	sp	m	n	p	Part No
UI 90/30	SS	31,0	30,0	89,0	1,5	59,0	68,0	95,5	U0900303
UI 90/35	SS	31,0	35,0	89,0	1,5	59,0	74,5	95,5	U0900353
UI 90/40	SS	31,0	40,0	89,0	1,5	59,0	79,0	95,5	U0900403
UI 90/45	SS	31,0	45,0	89,0	1,5	59,0	84,0	95,5	U0900453
UI 90/50	SS	31,0	50,0	89,0	1,5	59,0	89,0	95,5	U0900503
UI 90/55	SS	31,0	55,0	89,0	1,5	59,0	94,0	95,5	U0900553
UI 90/60	SS	31,0	60,0	89,0	1,5	59,0	100,0	95,5	U0900603
UI 90/75	SS	31,0	75,0	89,0	1,5	59,0	113,0	95,5	U0900753

Standard material: Nylon 6 glass reinforced

Dimensions in millimetres



UI 100 BOBBINS

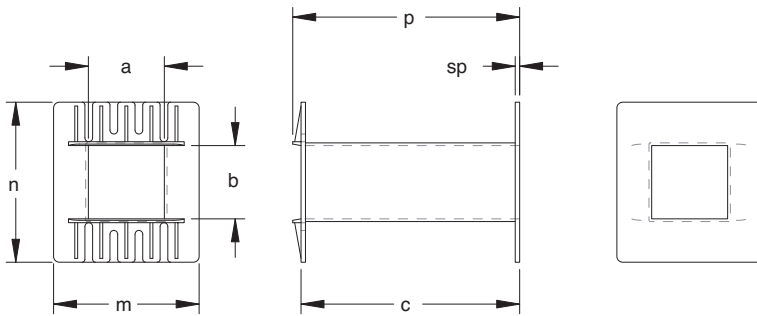

Bobbin Size	Art.N.	a	b	c	d	h	sp	m	n	p	Part No
UI 100/40	1314	41.0	40.0	99.5			2.0	78.0	86.0	99.5	U1000401
UI 100/50	1315	41.0	50.0	99.5			2.0	78.0	96.0	99.5	U1000402
UI 100/60	1316	41.0	60.0	99.5			2.0	78.0	106.0	99.5	U1000501
UI 100/70	1317	41.0	70.0	99.5			2.0	78.0	116.0	99.5	U1000502
UI 100/80	1318	41.0	100.0	99.5			2.0	78.0	146.0	99.5	U1000601

Standard material: Nylon 6 glass reinforced

Dimensions in millimetres

UI 120 BOBBINS

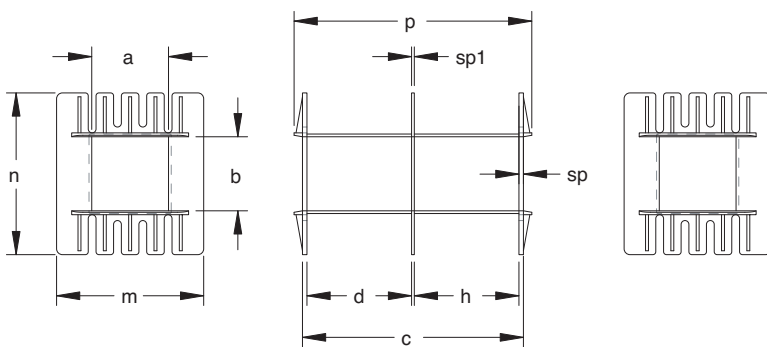

Bobbin Size	Type	a	b	c	d	h	sp/sp1	m	n	p	Part No
UI 120/40	SS	41.0	40.0	119.0			2.0	78.5	89.5	128.0	U1200401
UI 120/40	DS	41.0	40.0	119.0	53.0	60.5	2.0	78.5	89.5	128.0	U1200402
UI 120/50	SS	41.0	50.0	119.0			2.0	78.5	99.0	128.0	U1200501
UI 120/50	DS	41.0	50.0	119.0	53.0	60.5	2.0	78.5	99.0	128.0	U1200502
UI 120/60	SS	41.0	60.0	119.0			2.0	78.5	110.0	128.0	U1200601
UI 120/60	DS	41.0	60.0	119.0	53.0	60.5	2.0	78.5	110.0	128.0	U1200602
UI 120/75	SS	41.0	75.0	119.0			2.0	78.5	123.0	128.0	U1200751
UI 120/75	DS	41.0	75.0	119.0	53.0	60.5	2.0	78.5	123.0	128.0	U1200752

Standard material: Nylon 6 glass reinforced

Dimensions in millimetres



Metric Range

UI 150 BOBBINS

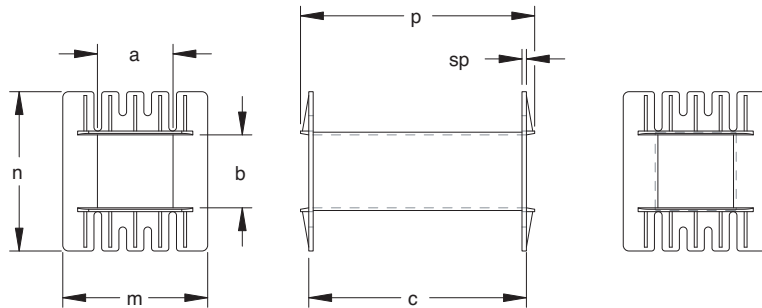

Bobbin Size	Type	a	b	c	sp	m	n	p	Part No
UI 150/50	SS	51.0	50.0	149.0	2.0	97.5	107.0	157.0	UI500501
UI 150/60	SS	51.0	60.0	149.0	2.0	97.5	117.0	157.0	UI500601
UI 150/70	SS	51.0	70.0	149.0	2.0	97.5	128.0	157.0	UI500701
UI 150/80	SS	51.0	80.0	149.0	2.0	97.5	138.0	157.0	UI500801
UI 150/90	SS	51.0	90.0	149.0	2.0	97.5	147.0	157.0	UI500901
UI 150/100	SS	51.0	100.0	149.0	2.0	99.0	157.0	157.0	UI501001

Standard material: Nylon 6 glass reinforced

Dimensions in millimetres

UI 180 BOBBINS

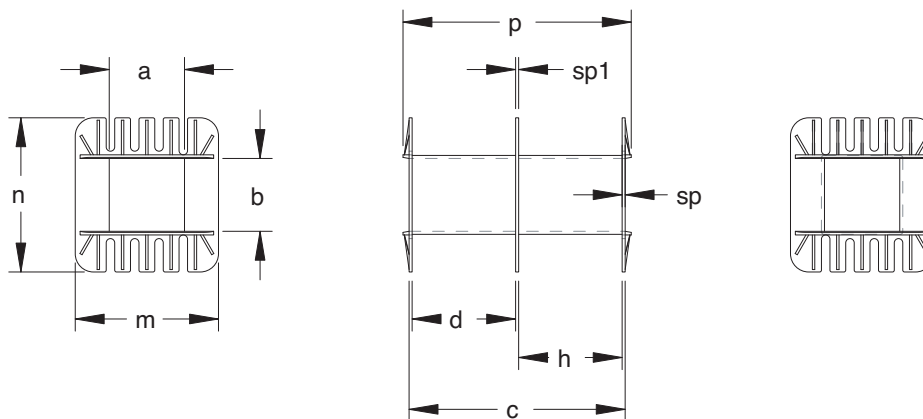

Bobbin Size	Type	a	b	c	d	h	sp/sp1	m	n	p	Part No
UI 180/60	SS	61.0	60.0	180.0			2.0	118.0	128.0	188.0	UI800601
UI 180/70	SS	61.0	70.0	180.0			2.0	118.0	137.0	188.0	UI800701
UI 180/70	DS	61.0	70.0	180.0	85.0	87.0	2.0	118.0	137.0	188.0	UI800702
UI 180/80	SS	61.0	80.0	180.0			2.0	118.0	149.0	188.0	UI800801
UI 180/90	SS	61.0	90.0	180.0			2.0	118.0	158.0	188.0	UI800901

Standard material: Nylon 6 glass reinforced

Dimensions in millimetres

Most products are available direct from stock with same day despatch
- please contact sales for details



UI 210 BOBBINS (Style 1)

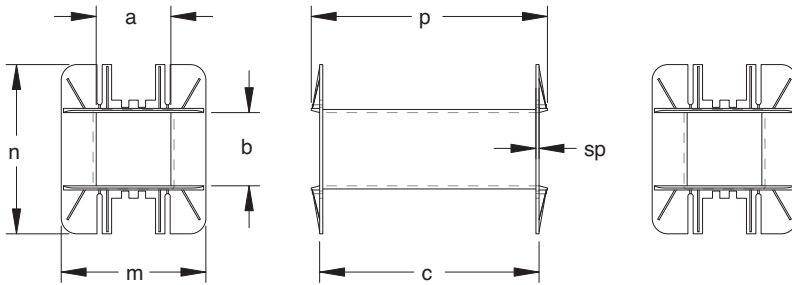

Bobbin Size	Type	a	b	c	sp	m	n	p	Part No
UI 210/70	SS	70.0	70.0	210.0	3.0	139.0	162.0	221.0	U2100701
UI 210/80	SS	70.0	80.0	210.0	3.0	139.0	172.0	221.0	U2100801
UI 210/90	SS	70.0	90.0	210.0	3.0	139.0	193.0	221.0	U2100901
UI 210/100	SS	70.0	100.0	210.0	3.0	139.0	193.0	221.0	U2101001

Standard materials: Nylon 6 glass reinforced

Dimensions in millimetres

UI 210 BOBBINS (Style 2)

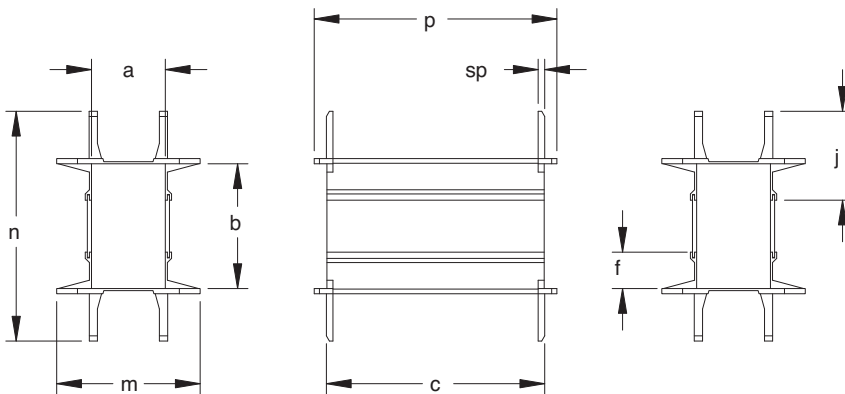

Bobbin Size	Type	a	b	c	f	j	sp	m	n	p	Assembly part no	End part No	Side Part No
UI 210/110	SS	71.0	110.0	210.0	35.0	81.0	3.0	139.0	202.0	221.0	U2101101	UE210000	US210110
UI 210/120	SS	71.0	120.0	210.0	35.0	81.0	3.0	139.0	212.0	221.0	U2101201	UE210000	US210120
UI 210/130	SS	71.0	130.0	210.0	35.0	81.0	3.0	139.0	222.0	221.0	U2101301	UE210000	US210130
UI 210/140	SS	71.0	140.0	210.0	35.0	81.0	3.0	139.0	232.0	221.0	U2101401	UE210000	US210140

Standard material: Nylon 6 glass reinforced

Dimensions in millimetres



UI 240 BOBBINS

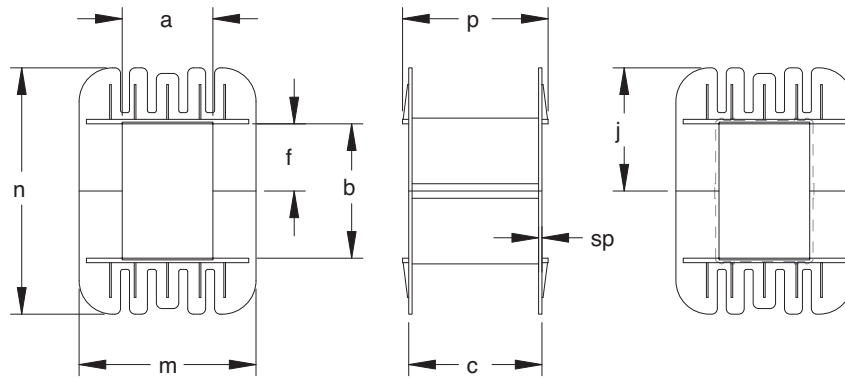

Bobbin Size	Type	a	b	c	f	j	sp	m	n	p	Assembly part no	End part No	Side Part No
UI 240/80	SS	81,5	80.0	240.0	40.0	100.0	3.0	160.0	200.0	252.0	U2400801	UE240000	US240080
UI 240/90	SS	81,5	90.0	240.0	40.0	100.0	3.0	160.0	210.0	252.0	U2400901	UE240000	US240090
UI 240/100	SS	81,5	100.0	240.0	40.0	100.0	3.0	160.0	220.0	252.0	U2401001	UE240000	US240100
UI 240/110	SS	81,5	110.0	240.0	40.0	100.0	3.0	160.0	230.0	252.0	U2401101	UE240000	US240110
UI 240/120	SS	81,5	120.0	240.0	40.0	100.0	3.0	160.0	240.0	252.0	U2401201	UE240000	US240120
UI 240/130	SS	81,5	130.0	240.0	40.0	100.0	3.0	160.0	250.0	252.0	U2401301	UE240000	US240130
UI 240/140	SS	81,5	140.0	240.0	40.0	100.0	3.0	160.0	260.0	252.0	U2401401	UE240000	US240140
UI 240/150	SS	81,5	150.0	240.0	40.0	100.0	3.0	160.0	270.0	252.0	U2401501	UE240000	US240150

Standard materials: Nylon 66 glass reinforced / Nylon 66 glass reinforced to UL94V0

Dimensions in millimetres

UI 300 BOBBINS

Contact Sales Office
for details and availability.